

# 4i Platform Industrial IoT



## DOT V3.X SERIES

### Technical Manual

#### Brief

Designed for industrial purposes, DOT is a stable, plug and play device for digital and analog data acquisition with isolated inputs and outputs. Although this device was designed to work with an external power, the low power consumption and its internal battery allows it to keep working for days after removing the external power supply. DOT is capable of switching between power sources without losing data.

[www.4iplatform.com](http://www.4iplatform.com)  
[support@4iplatform.com](mailto:support@4iplatform.com)

## DOT V3.X Series

---

### Features

- 7 relay contact digital inputs. (factory configuration)
  - 2 Opto isolated analog inputs 0-10V/4-20mA (factory configuration)
  - 1 Relay output.
  - Sampling rate up to 100 ms.
  - 2.4 GHz wireless mesh network.
  - Remote centralized configuration.
  - Wide 9V to 34V DC input voltage range.
-

## Contents

---

### Overview

Pinout  
Pin Assignments  
Specifications  
Absolute Minimum and Maximum Ratings  
Electrical Characteristics  
Analog Inputs Accuracy

### Interface

USB Connection  
Led Signals

### Operation Modes

Pin-Hibernate Mode  
Wake Up From Hibernation

### Mounting and Installation

Installation  
Physical Dimensions  
Connection Diagram

### Relevant Information

Descriptive Label  
Basic Troubleshooting  
Recommendations, Warnings and Restrictions  
Warranty Information  
Manufacturer

## Pinout

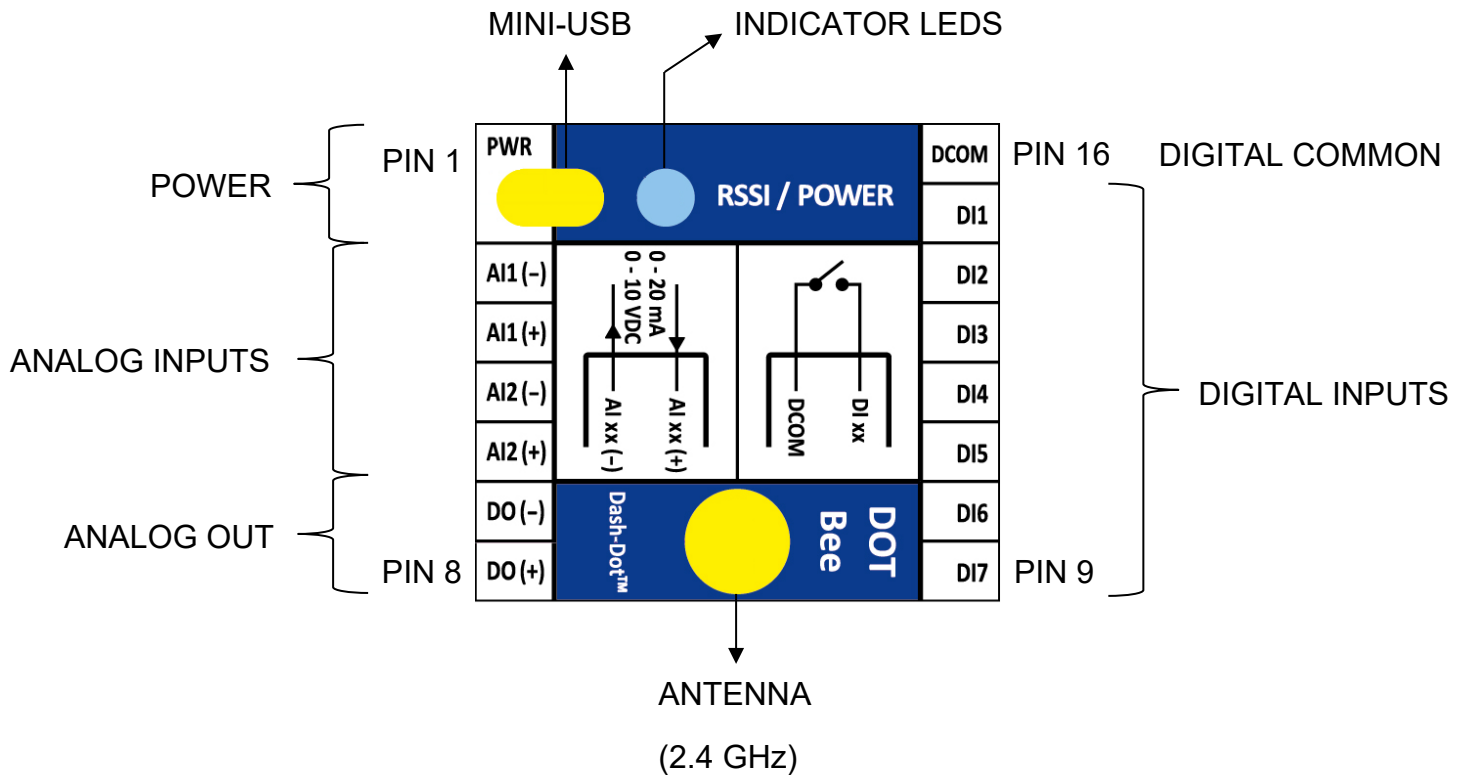

## Pin Assignments

Pin #	Name	Direction	Description
1	PWR	-	Power Supply
2	PWR	-	Power Supply
3	AI1(-)	IN	Analog Input 1 (-)
4	AI1(+)	IN	Analog Input 1 (+)
5	AI2(-)	IN	Analog Input 2 (-)
6	AI2(+)	IN	Analog Input 2 (+)
7	DO(-)	OUT	Relay Out (-)
8	DO(+)	OUT	Relay Out (+)
9	DI7	IN	Digital Input 7 / wakeup (one time)
10	DI6	IN	Digital Input 6
11	DI5	IN	Digital Input 5
12	DI4	IN	Digital Input 4
13	DI3	IN	Digital Input 3
14	DI2	IN	Digital Input 2
15	DI1	IN	Digital Input 1
16	DCOM	IN	Digital Common

## Specifications

Parameter	Conditions	Min	Typ	Max	Units
Weight	No antenna	-	227.5	-	Grams
Frequency Band	-	2.4	-	2.5	GHz
Reconnection Time(*)	After power down	2	4	10	Sec.

Notes:

Reconnection times can be longer if the DOT is in Pin-Hibernate mode.

## Absolute Minimum and Maximum Ratings

Parameter	Min	Max	Units
Supply Voltage	9	34	V
Output Current	-	150	mA
Output Blocking Voltage	-	400	V

Notes:

1. Exceeding the absolute maximum rating may damage the device.
2. The device is not guaranteed to function outside its operating rating.
3. Absolute maximum rating is intended for voltage transients only.

## Electrical Characteristics

V<sub>in</sub> = 12V; Out = Low; All DI = High, RSSI led = On; T<sub>j</sub> = 25°C

Parameter	Conditions	Min	Typ	Max	Units
Operating Voltage	-	2.4	3.2	3.6	V
Operating Current	External Power	58	60	66	mA
Input Impedance	4-20mA	250	-	1300	Ω
	0-10V	99.6	100.7	102	KΩ
Output Impedance	-	11	18	24	Ω

## Analog Inputs Accuracy

Parameter	Conditions	Min	Typ	Max	Units
Measurement error	4-20mA	0	0.25	0.5	%
	0-10V	0	0.2	0.3	%
Resolution	-	-	9.77	-	mV

## USB Connection

---

DOT 3<sup>rd</sup> generation are USB 2.0 compatible and have a MINI-USB connector in the front. While DOT is plugged, it can be powered in 3 possible ways:

- 1) External power: Will energize DOT's electronics, charge the battery and take control of the USB power line.
- 2) Battery running: Operates like case (1), but subject to the battery life.
- 3) USB: Just take the necessary power to keep DOT running. Battery will not be charged.

## Led Signals

---

DOT has a green/red multicolor led for status information.

- Green led turns on when DOT is being powered by an external source.
- Red led is a received signal strength indicator. It can be turned off for lower current consumption, by commands from website application.

## Pin-Hibernate Mode

---

Pin-Hibernate configuration is the lowest power consumption state of the DOT. In this mode, no data is received or sent.

In order to reducing power consumption, pin assignment is modified as is shown in the table below.

Pin #	Name	Direction	Description
1	PWR	-	Power Supply
2	PWR	-	Power Supply
9	DI7	IN	Pin Sleep Control Line
13	DI3	IN	On/Sleep Indicator
16	DCOM	IN	GND

Remaining pins are disabled.

## Wake Up From Hibernation

To wake up a DOT, follow these instructions.

1° DASH must be ready and operative. DOT hasn't any battery charge indicator, so, to make sure that it is being well powered, is advisable to use an external power source in the first time you use.

2° Place a wire between DI7 and DCOM until RSSI led blinks low; it means that DASH is downloading the new firmware configuration. From this moment, the wire is not necessary anymore.

3° Once the download is done, the RSSI led turns off; DOT is restarting. After that, RSSI led will increase its bright to its regular level. Now DOT is ready.

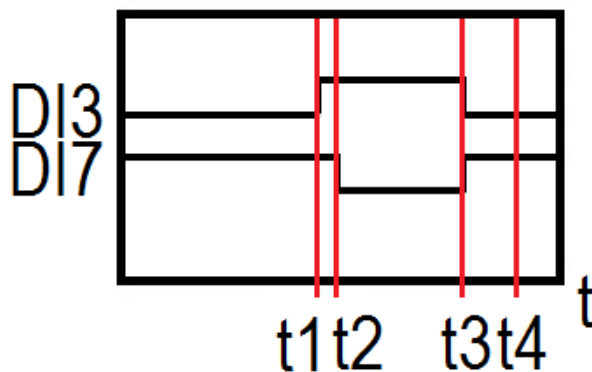

In the figure above, t1, t2 and t3 represents the following events:

- t1 – Time when DI7 is unconnected or asserted (high).
- t2 – Time when the DOT enters sleep.
- t3 – Time when DI7 is connected to DCOM or de-asserted (low).
- t4 – Time when DOT sends heartbeat.

Note: If a DOT is waked-up and there is no DASH to communicate with, it will return to its previous state of Pin-Hibernate.

## Installation

---

Day zero configuration provides a comprehensive interface to make the installation process in six easy steps.

1° Connect the DOT to a power supply to make sure that the batteries are fully charged.

2° Verify that the DOT is wirelessly linked to a DASH checking that the RSSI led is on. If it is not, try following the steps on “Wake Up From Hibernation”.

3° Mount the DOT on the panel. Check always that the RSSI is blinking. If it is not, probably the signal strength is not enough for a fluid communication.

4° Connect the DOT to a power source (9-34VDC). PAY ATTENTION! Connecting the power in a wrong terminal may damage the device. Power pins (+) and (-) are switchable.

5° Connect the Analog and Digital Inputs.

6° Your variables are being displayed in the Day Zero website (<http://www.dzsupervision.com>), or IHBOX server.



## Physical Dimensions

---

Height: 107.5mm

Height + Antenna holder = 117.5mm

Length: 75mm

Width: 45mm

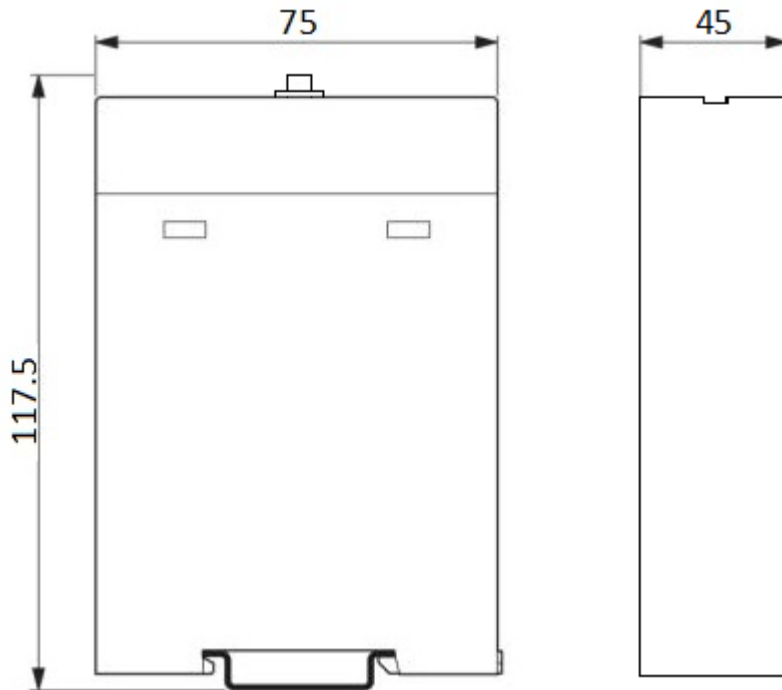

Dimensions are in millimeters.

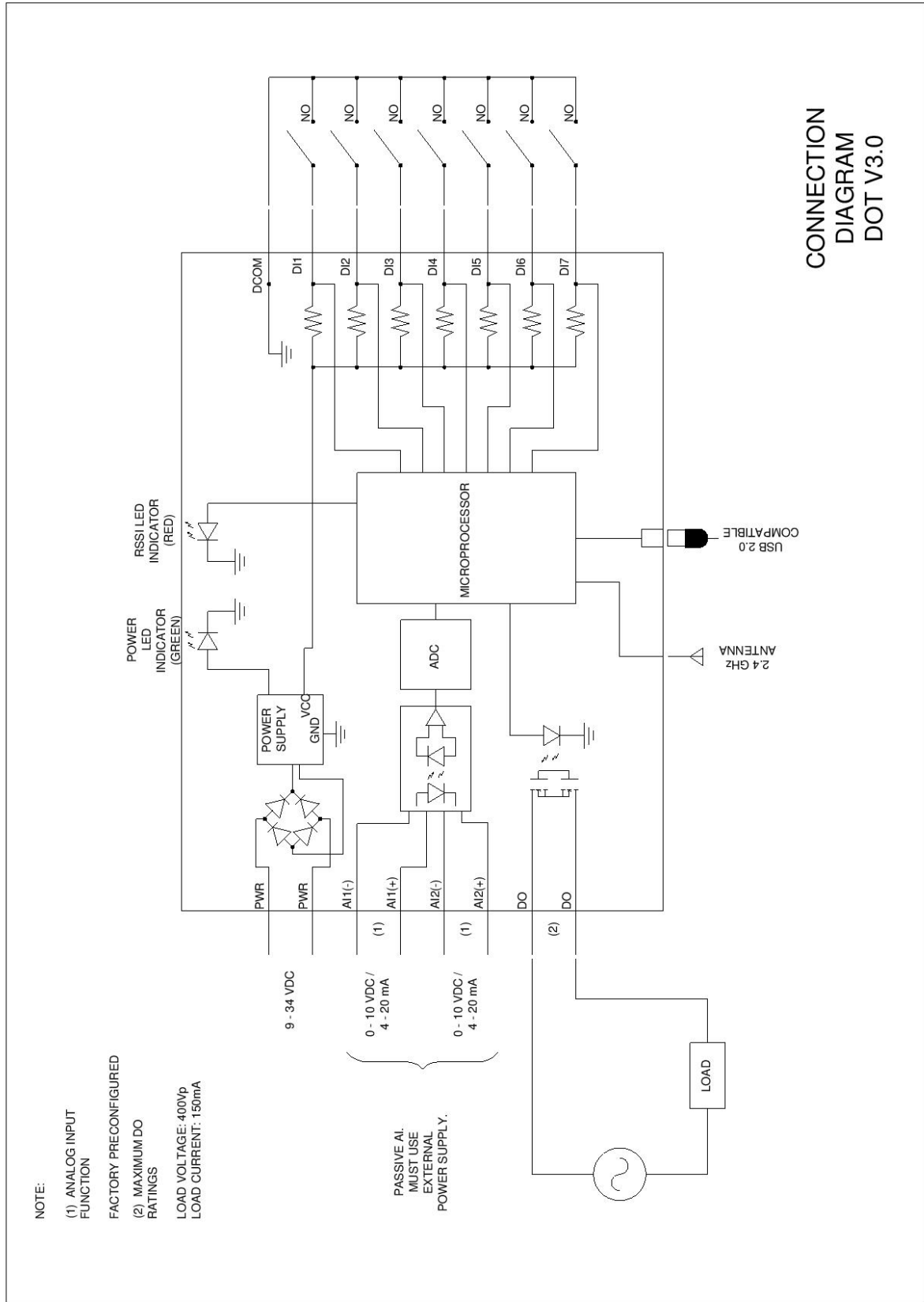

## Descriptive Label

On the top of the housing is a silver-black label. This label contains relevant information about the device.

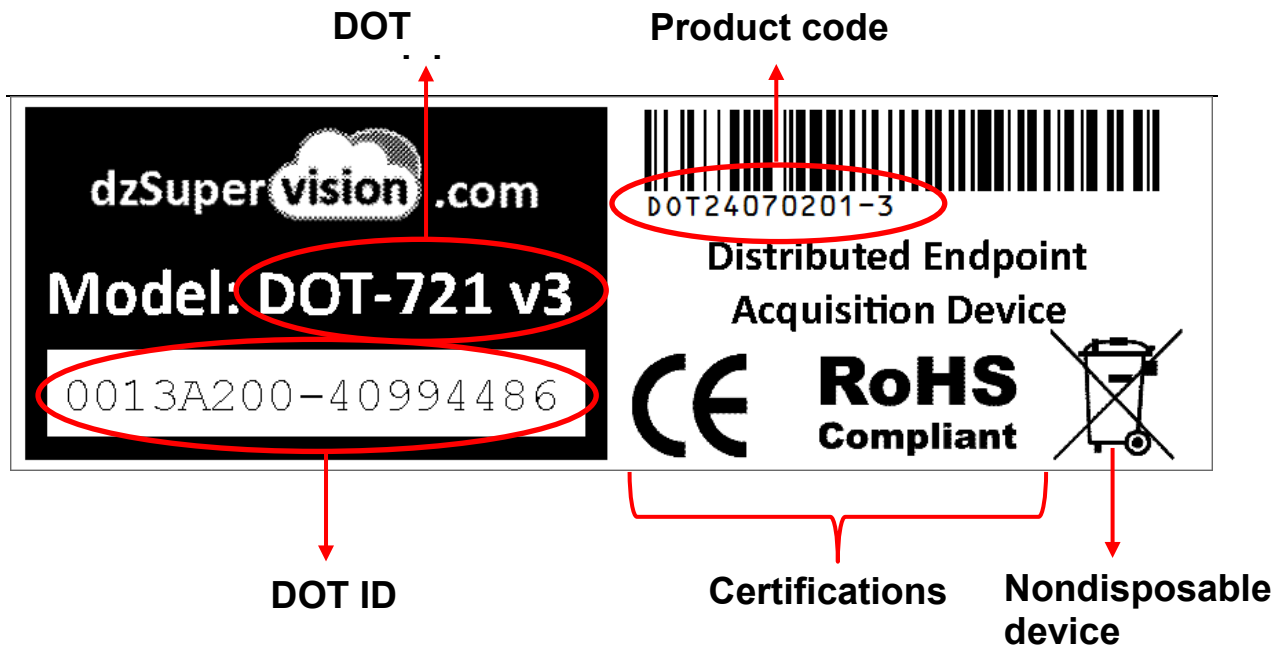

## Basic Troubleshooting

Symptoms	Possible Reasons	Solutions
DOT doesn't communicate.	Discharged battery.	Connect the device to an external power supply (9-34 VDC).
	DOT is too far from a DASH.	Bring the DOT near to a DASH. When RSSI led starts blinking, move it away until RSSI led turns off, to measure the operative range.
	Antenna is disconnected or damaged.	Check that the antenna is well screwed. If it is, try replacing for a new one.
	DOT was never waked up from factory configuration.	Go to "Wake Up From Hibernation" (page 6).
RSSI led doesn't blink.	Discharged battery.	Connect the device to an external power supply (9-34 VDC).
	RSSI led is off.	Restore DOT configuration.
	Communication issues.	See "DOT can't communicate".
Can't wake up from factory configuration.	Discharged battery.	Connect the device to an external power supply (9-34 VDC).
	Wire between DI7 and DCOM is damaged.	Replace the wire.
	Wire between DI7 and DCOM is extracted before RSSI signal.	Hold the wire connected until RSSI led blinks.
Wrong measurement of analog inputs.	Wrong connection.	Analog inputs have polarity. See "Connection Diagram" (page 9).
	Wrong hardware configuration.	Analog inputs are factory configured in 0-10V or 4-20mA versions. Please contact seller.

## Recommendations, Warnings and Restrictions.

### FCC-Approved Antennas (2.4 GHz)

For complying with FCC regulations, use the tables below for choose the correct antennas. If he antenna is mounted at least 20cm (8 in.) from nearby persons, the application is considered a mobile application. Antennas not listed in the table must be tested to comply with FCC Section 15.203 (Unique Antenna Connectors) and Section 15.247 Emissions).

Ampexa does not carry all of these antenna variants. Contact Ampexa for available antennas.

### Antennas approved for use with the DOT 3.x Series (Cable loss is not required).

PANEL CLASS ANTENNAS				
Part Number	Type(Description)	Gain	Min Separation	Cable-Loss
A24-P8SF	Flat Panel	8.5 dBi	2 m	N/A
A24-P8NF	Flat Panel	8.5 dBi	3 m	N/A
A24-P13NF	Flat Panel	13.0 dBi	4 m	N/A
A24-P14NF	Flat Panel	14.0 dBi	5 m	N/A

OMNI-DIRECTIONAL ANTENNAS				
Part Number	Type(Description)	Gain	Min Separation	Cable-Loss
A24-F15NF	Omni-Directional (Fiberglass base station)	15.0 dBi	2 m	N/A

### Antennas approved for use with the DOT 3.x Series (Channels 11 - 25).

YAGI and PANEL CLASS ANTENNAS				
Part Number	Type(Description)	Gain	Min Separation	Cable-Loss
A24-Y6NF	Yagi (6-element)	8.8 dBi	2 m	N/A
A24-Y7NF	Yagi (7-element)	9.0 dBi	2 m	N/A
A24-Y9NF	Yagi (9-element)	10.0 dBi	2 m	N/A
A24-Y10NF	Yagi (10-element)	11.0 dBi	2 m	N/A
A24-Y12NF	Yagi (12-element)	12.0 dBi	2 m	N/A
A24-Y13NF	Yagi (13-element)	12.0 dBi	2 m	N/A
A24-Y15NF	Yagi (15-element)	12.5 dBi	2 m	N/A
A24-Y16NF	Yagi (16-element)	13.5 dBi	2 m	N/A
A24-Y16RM	Yagi (16-element, RPSMA connector)	13.5 dBi	2 m	N/A
A24-Y18NF	Yagi (18-element)	15.0 dBi	2 m	N/A
A24-P15NF	Flat Panel	15.0 dBi	2 m	N/A
A24-P16NF	Flat Panel	16.0 dBi	2 m	N/A
A24-P19NF	Flat Panel	19.0 dBi	2 m	N/A

**Antennas approved for use with the DOT 3.x Series (Channels 26).**

YAGI and PANEL CLASS ANTENNAS				
Part Number	Type(Description)	Gain	Min Separation	Cable-Loss
A24-Y6NF	Yagi (6-element)	8.8 dBi	2 m	N/A
A24-Y7NF	Yagi (9-element)	9.0 dBi	2 m	N/A
A24-Y9NF	Yagi (9-element)	10.0 dBi	2 m	N/A
A24-Y10NF	Yagi (10-element)	11.0 dBi	2 m	N/A
A24-Y12NF	Yagi (12-element)	12.0 dBi	2 m	N/A
A24-Y13NF	Yagi (13-element)	12.0 dBi	2 m	N/A
A24-Y15NF	Yagi (15-element)	12.5 dBi	2 m	N/A
A24-Y16NF	Yagi (16-element)	13.5 dBi	2 m	N/A
A24-Y16RM	Yagi (6-element, RPSMA connector)	13.5 dBi	2 m	N/A
A24-Y18NF	Yagi (18-element)	15.0 dBi	2 m	N/A
A24-P15NF	Flat Panel	15.0 dBi	2 m	N/A
A24-P16NF	Flat Panel	16.0 dBi	2 m	N/A
A24-P19NF	Flat Panel	19.0 dBi	2 m	N/A

**RF Exposure WARNING:**

To satisfy FCC RF exposure requirements, a separation distance of 20 cm or more should be maintained between the antenna of this device and persons during device operation. To ensure compliance, operations at closer than this distance are not recommended.

**Restrictions**

**France:** Outdoor use limited to 10 mW EIRP within the band 2454-2483.5 MHz.

**Norway:** Norway prohibits operation near Ny-Alesund in Svalbard. More information can be found at the Norway Posts and Telecommunications site ([www.npt.no](http://www.npt.no)).

**Italy:** For private use, a general authorization is required if WAS/RLANs are used outside own premises. For public use, a general authorization is required.

**Russian Federation:**

- Maximum mean EIRP density is 2 mW/MHz, maximum 100 mW EIRP.
- Maximum mean EIRP density is 20 mW/MHz, maximum 100 mW EIRP permitted to use SRD for outdoor applications only, for purposes of gathering telemetry information for automated monitoring and resources accounting systems or security systems.
- Maximum mean EIRP density is 10 mW/MHz, maximum 100 mW EIRP for indoor applications.

**Ukraine:** EIRP must be less than or equal to 100 mW with built-in antenna, with amplification factor up to 6 dBi.

## Warranty Information

---

### 1 Year Warranty

---

DOT and DASH devices, from Ampexa, are warranted against defects in materials and workmanship under normal use, for a period of 1 year from the date of purchase. In the event of a product failure due to materials or workmanship, Ampexa will repair or replace the defective product. For warranty service, return the defective product to Ampexa, shipping prepaid, for prompt repair or replacement.

The foregoing sets forth the full extent of Ampexa's warranties regarding the product. Repair or replacement at Ampexa's option is the exclusive remedy.

THIS WARRANTY IS GIVEN IN LIEU OF ALL OTHER WARRANTIES, EXPRESS OR IMPLIED, AND AMPEXA SPECIFICALLY DISCLAIMS ALL WARRANTIES OF MERCHANTABILITY OR FITNESS FOR A PARTICULAR PURPOSE. IN NO EVENT SHALL AMPEXA-AMEPXA, ITS SUPPLIERS OR LICENSORS BE LIABLE FOR DAMAGES IN EXCESS OF THE PURCHASE PRICE OF THE PRODUCT, FOR ANY LOSS OF USE, LOSS OF TIME, INCONVENIENCE, COMMERCIAL LOSS, LOST PROFITS OR SAVINGS, OR OTHER INCIDENTAL, SPECIAL OR CONSEQUENTIAL DAMAGES ARISING OUT OF THE USE OR INABILITY TO USE THE PRODUCT, TO THE FULL EXTENT SUCH MAY BE DISCLAIMED BY LAW. SOME STATES DO NOT ALLOW THE EXCLUSION OR LIMITATION OF INCIDENTAL OR CONSEQUENTIAL DAMAGES. THEREFORE, THE FOREGOING EXCLUSIONS MAY NOT APPLY IN ALL CASES. This warranty provides specific legal rights. Other rights which vary from state to state may also apply.

## Manufacturer

---

### Ampexa

---

Argentina Office:

Cuidad de la Paz 1965 3°D

Buenos Aires, Argentina.

Phone: +54 (11) 5263-0222

Fax: +54 (11) 5263-0222

USA Office:

800 Old Pond Road - Suite 706K

Bridgeville, PA 15017 USA

Phone: (412)257-2377

Fax : (412)257-2388

Website: <http://www.ampexa.com>